

AEC FLOWTRIGGER INSTALLATION & OPERATION MANUAL

NOTICE

This bulletin contains important safety information and should be read and understood by all installation and operation personnel.



ATMOSPHERE ENGINEERING COMPANY

Phone: 414-331-2457; Fax: 414-332-2457

Email: sales@atmoseng.com Web: www.atmoseng.com

TABLE OF CONTENTS

NOTICE, CAUTIONS, AND WARNINGS..... 3

EXPRESS WARRANTY ON ATMOSPHERE ENGINEERING EQUIPMENT..... 4

DESCRIPTION 6

SPECIFICATIONS 6

GENERAL PREVENTATIVE MAINTENANCE.....10

INSTALLATION

 MECHANICAL CONNECTION 7

 ELECTRICAL WIRING..... 8

OPERATION

 FLOW ALARM..... 9

ADDITIONAL DOCUMENTATION

NOTICE, CAUTIONS, AND WARNINGS

NOTICE

This Bulletin contains important safety information and should be read and understood by all individuals who install, use, or service this equipment.

Failure to follow the precautions and recommendations of this manual may subject personnel and property to dangerous conditions.

WARNING

It is always recommended that users install appropriate lockable gas shut off valves for positive gas shut off.

TECHNICAL ASSISTANCE

Contact Atmosphere Engineering Company with any questions or concerns regarding the installation, operation, or setup of the FurnaceMeter™ mixing system.

Phone: 414-331-2457 Fax: 414-332-2457 E-Mail: sales@atmoseng.com

EXPRESS WARRANTY ON ATMOSPHERE ENGINEERING EQUIPMENT

ATMOSPHERE ENGINEERING COMPANY (AEC) warrants its products for a period of one (1) year from the date of shipment from AEC to the original purchaser to be free from defects in material and workmanship under normal recommended use, service, inspection, and maintenance. Normal recommended use, service, inspection, and maintenance, mean:

1. Not to be used in excess of nor below the rated capacity, pressure, and temperature ranges specified in the applicable quotation, purchase order, acknowledgment, marketing literature, nameplate, specification sheet, or the Installation, Operation, Inspection, and Maintenance Manual (THE MANUAL); and
2. Using only clean gases free of solids and other contaminants not considered constituents of the gas; and
3. Installation, operation, inspection, and maintenance in compliance with THE MANUAL; and
4. The AEC products being used only in:
 - a. Ambient environments lower than 132 ° Fahrenheit (54 °Celsius) unless specifically designed and so labeled by AEC for higher temperatures; and
 - b. Non-corrosive environments; and
 - c. Completely protected from moisture, rain, snow, or other outside environments; and
 - d. Not to be used below 32 ° Fahrenheit (0 °Celsius) unless precautions are taken for low temperature conditions as shown in THE MANUAL.
5. Being used only for applications permitted by THE MANUAL or other AEC literature or special applications approved in a separate written authorization by AEC.

WARRANTY EXCEPTIONS

This Warranty does not apply to damage caused by any or all of the following circumstances or conditions:

1. Freight damage;

2. Parts, accessories, materials, or components not obtained from nor approved in writing by AEC;
3. Any consequential or incidental damages including but not limited to loss of use, loss of profits, loss of sales, increased costs, arising from the use of any product system or other goods or services manufactured, sold, or provided by AEC;
4. Misapplication, misuse, and failure to follow THE MANUAL or other literature, instructions, or bulletins (including drawings) published or distributed prior to THE MANUAL.

The exclusive remedy under this Warranty or any other express warranty is the repair or replacement without charge for labor and materials of any AEC parts found upon examination by AEC to have been defective. Since certain AEC equipment is heavy, bulky and not deliverable by U.S. mail or other parcel service, AEC equipment may be returned only upon written consent of AEC and then only to the location designated by AEC. Generally such consent will be given only upon the condition that the customer assume and prepay all carrier charges and responsibility for damage in transit.

Purchasers of AEC products, equipment, goods, or services waive subrogation on all items covered under their own or any other insurance.

DISCLAIMER

THIS WARRANTY IS EXCLUSIVE. AEC EXPRESSLY DISCLAIMS ANY AND ALL OTHER WARRANTIES WHETHER EXPRESS OR IMPLIED INCLUDING ANY IMPLIED WARRANTY OF MERCHANTABILITY OR FITNESS FOR A PARTICULAR PURPOSE OR ANY PURPOSE.

No person, including and dealer, seller, or other representative of AEC is authorized to make, on behalf of AEC, any representations beyond those contained in AEC literature and documents or to assume for AEC any obligations or duties not contained in this Warranty and Warranty Policy.

AEC reserves the right to make design and other changes, modifications or improvements to its

(Continued on page 5)

EXPRESS WARRANTY ON ATMOSPHERE ENGINEERING EQUIPMENT

(Continued from page 4)

products, services, literature, or systems, without any obligation, to furnish or install same on any previously sold or delivered products or systems.

LIMITATION OF LIABILITY

It is expressly agreed that the liability of AEC is limited and AEC does not function as an insurer. The purchaser and/or user agree that AEC is not liable for loss, harm, or damage due directly or indirectly to any occurrence or consequences there from. If AEC should be found liable to anyone on any theory (except any express warranty where the remedy is set forth in Section 2 of this Warranty and Warranty Policy) for loss harm or damage, the liability of AEC shall be limited to the lesser of the actual loss, harm or damage or the purchase price of the involved AEC equipment or service when sold (or when service performed) by AEC to its customer. This liability is exclusive and regardless of cause or origin resulting directly or indirectly to any person or property from:

1. The performance or nonperformance of any obligations set forth in this Warranty and Warranty Policy;
2. Any agreement including specifications between AEC and the customer;
3. Negligence, active, passive or otherwise of AEC or any of its agents or employees;
4. Breach of any judicially imposed warranty or covenant of workmanship, durability or performance; and
5. Misrepresentation (under the Restatement, common law or otherwise) and/or strict liability involvement;
6. Liability for fraud-in-the-inducement.

WARRANTY FIELD SERVICE

If warranty Field Service at the request of the purchaser or user is rendered and the difficulty is found not to be with AEC's product, the purchaser shall pay the time and expense (at the prevailing rate at the time of the service) of AEC's field representative(s). Charges for service, labor, and other expenses that have been incurred by the purchaser, its customer or agent without written approval of AEC will not be accepted. The OEM or other reseller is responsible for transmitting installation and operating instructions, THE MANUAL or other service literature supplied by AEC with the equipment.

DESCRIPTION

The FlowTrigger is a precision instrument designed specifically to meet the rugged requirements of industrial flow monitoring for heat treating applications. The FlowTrigger utilizes differential pressure flow measurement across a fixed orifice to give a precise and reliable flow setpoint in an inline configuration.

SPECIFICATIONS

Power Required	24 VDC @ 150 mA
Medium Temperature Limits.....	0°F to 140°F
Ambient Temperature Limits	0°F to 140°F
Contact Rating.....	Variable (Dependent on Specs)
Flow Switch Contact Rating.....	10 A @ 120/240 VAC (28 VDC)
Flow Switch Pressure Limits	45" w.c. (11.2 kPa) continuous; 10 psig (68.95 kPa) surge.

MAINTNANCE

General Preventative Maintenance

The FlowTrigger is designed to be a generally maintenance-free instrument. To ensure many years of reliable performance it is recommended that precautions be taken to keep the pressure switch assembly, including the upstream and downstream piping, clean and free from carbon or water contamination.

INSTALLATION

MECHANICAL CONNECTION

The FlowTrigger is shipped as a complete unit and ready to be mounted and plumbed per your local codes for the gas or liquid to be monitored. It is recommended that the following items be considered to ensure proper mechanical operation.

- Inspect the instrument for any obvious damaged or missing components.
- Attach pipe fittings to the inlet and outlet of the FlowTrigger as identified in Figure 2 below. It is acceptable to utilize bushings or reducers at the FlowTrigger ports to accommodate the desired pipe size. However, undersized piping may limit the maximum flow rate capability. Consult pipe sizing charts or contact Atmosphere Engineering to ensure that the desired flow rates will not be compromised.
- Ensure that the inlet pressure is within the limits of the installed FlowTrigger.

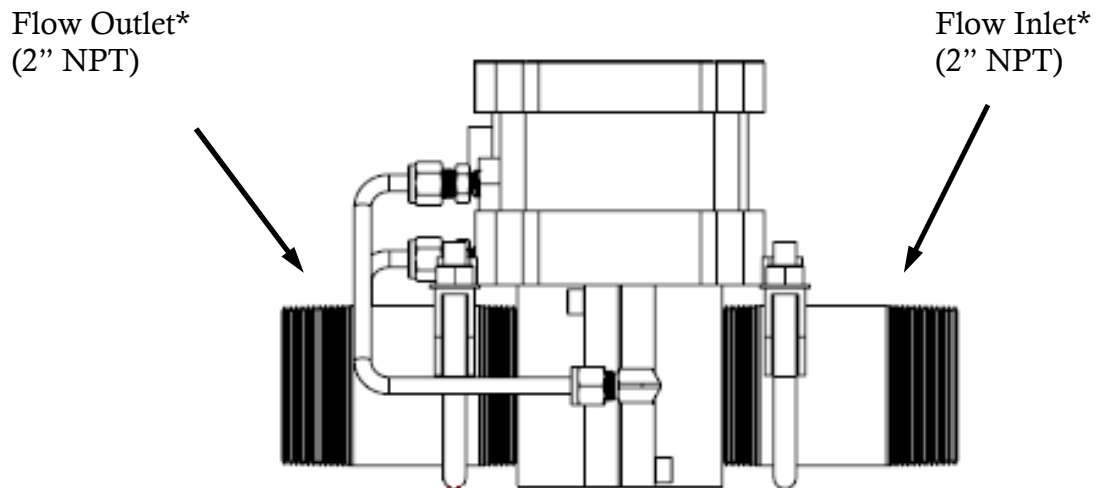

**Flow direction can be modified (must be specified prior to build)*

Figure 2

INSTALLATION

ELECTRICAL WIRING

The electrical connections are made to the terminals provided inside the pressure switch enclosure. A 1/2" female NPT conduit connection is provided in the side of the pressure switch. Figure 3 below shows a diagram of the terminal connections.

Note: Switch requires 24VDC power for operation of the contact switch. The 24 VDC is wired to the +/- terminals in the switch.

Contact Ratings: 10A @ 120/240 VAC

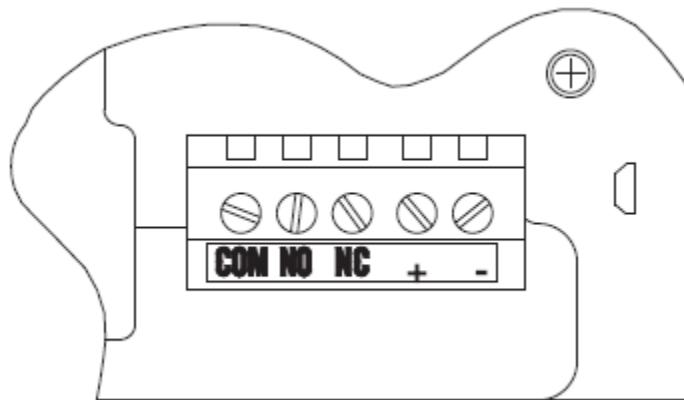

Figure 3

OPERATION

The FlowTrigger is a differential pressure flow switch that utilizes a custom calibrated orifice assembly designed specifically for furnace atmosphere control systems. The assembly has an integrated flow rate alarm.

Flow Alarm

The FlowTrigger is provided with a flow alarm output that can be used to trigger a relay. When in non-alarm state, the relay coil will be energized if wired NO. Conversely, in the alarm state the relay will be de-energized. A normally open contact could then be used to power a relay.

The flow alarm set points can be set by adjusting the range adjustment screw on the differential pressure switch as shown in Figure 4 below.

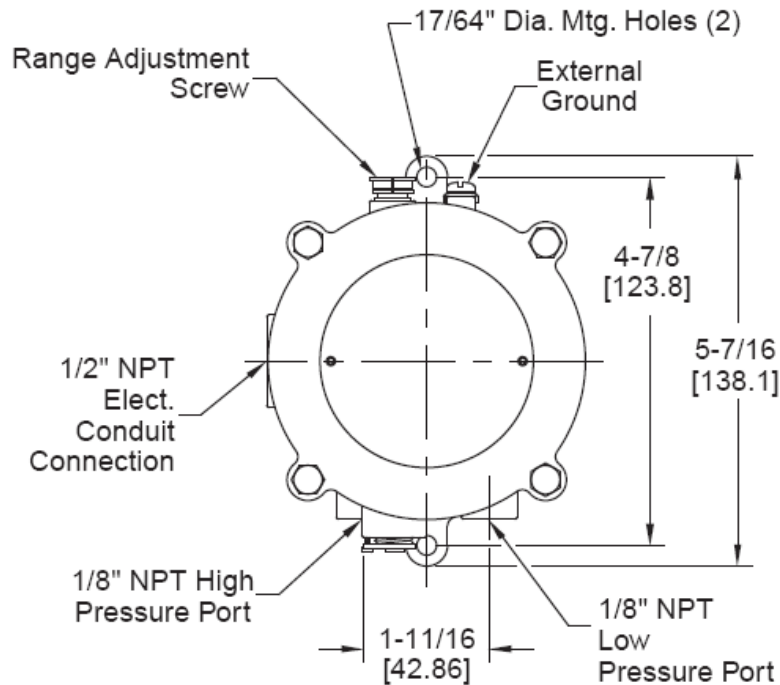

Figure 4